

JH PROCESS

SEALLESS & VALVELESS SELF PRIMING CENTRIFUGAL PUMP

SUPERIOR ANTI-CORROSIVE CONSTRUCTION

NO SEAL

NO VALVE



NO PROBLEM

YD-NSF/SF

- YD-25NSF**
- YD-40NSF**
- YD-50NSF**
- YD-80SF**
- YD-100SF**

FEATURES

High Quality resin construction

The entire pump and its component parts are flawlessly molded with an all resin construction. The pump's stability and quality are assured even in the harshest conditions.

All necessary measures taken for thermal expansion

Because the resin is resistant to high temperatures and is constructed to absorb thermal expansion, the pump is capable of handling high temperature solutions and chemicals.

Maintenance Free

Constructed with no consumable parts (such as mechanical seals), the pump is free from problems such as leaks, wear and tear, and excess heat. This makes maintenance and inspection an incredibly easy task with very low maintenance costs.

Valveless

This patented VALVELESS feature have been a World Chemical trademark since 1971. Because of its unique priming mechanism, this pump does not require any foot valves. Also, the built-in check valve increases priming speed and reduces back-flow velocity to retain maximum liquid in the priming chamber at pump shutdown.

Uniquely resistant to high temperatures

Our originally engineered design has the unique capability of constantly and smoothly self-priming and suctioning even in temperatures as high as 203° F(95° C).

Resistant to wide range of chemicals

Parts such as the pump base and the motor bracket that come in contact with chemical solvents are constructed with a high resistant resin. Thus the pump will not erode from chemicals or atmospheric gases, and can also be used with hard-to-handle chemicals such as sulfuric acids, nitric acids, caustic sodas, hydrofluoric acids and electro-less nickel plating solutions.

The Principle of Self-Priming, born of original ideas

The "NSF/SF SERIES" is a uniquely developed sealless & valveless self-priming centrifugal chemical pump. The primed water that fills the whole interior of the pump moves to the self-priming chamber guided by the impeller after the pump is turned on. In the self-priming chamber, the air and water separate as they rotate. The water is propelled into the impeller as it leaves the self-priming rotational outlet located on the bottom of the pump, and continues its repetitive cycle of self-priming. Air from the shaft is sealed by the seal blades during self-priming. As an added measure, a balance hole is constructed on the casing to release air into the self-priming chamber, ensuring that the self-priming operation is not affected. While the pump is not in use, the siphon break located on the interior of the self-priming chamber and the suction chamber blocks the backflow from the siphoning action. Water that is necessary for the subsequent prime remains in the suction chamber for smooth pumping.

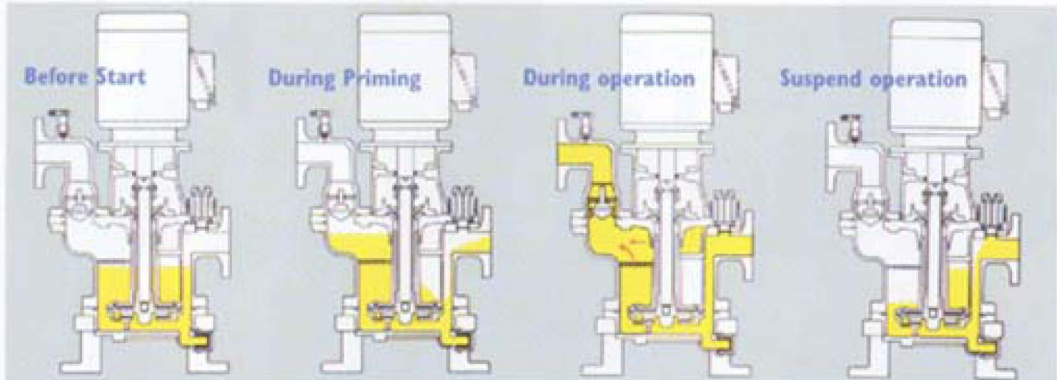

Pump is filled with water.

Just as the pump is turned on, the liquid in the suction chamber is sucked up, as the rotational movement creates a stronger vacuum seal.

All of the air in the main body of the pump is discharged and will allow normal smooth operation. Should even a little amount of air enter, it will be discharged without causing any operational difficulty.

When the pump is stopped, the siphon break will minimize the liquid backflow and secure enough liquid in the suction chamber for the next prime.

EXAMPLES OF USE

Transferring/Circulating high temperature plating liquid to a filtering tank.



Pumping, transport from a drainage tank or a chemical tank.

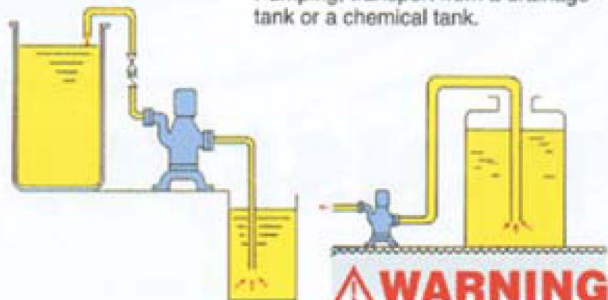

WARNING
THIS USE NOT APPLICABLE

A. Siphon Break

The siphon break, connected to the self-priming chamber and the suction chamber, uses the outflow as a liquid seal, always preserving a state of vacuum in the suction chamber when self priming.

When stopping, the suction chamber makes use of the force of the backflow and the air traveled through this siphon break to ensure that the primed liquid remain inside the suction chamber.

If the siphon break gets clogged through crystallization or with foreign particles, the amount of primed liquid will decrease. In such cases, a convenient cleaning plug should be used to unclog the debris.

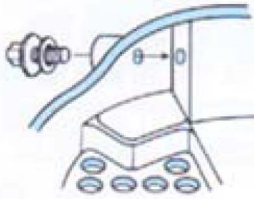

B. Separating Board

This component, used to separate air and chemical mixtures through differences in specific gravity, is secured inside the self-priming chamber.

C. Balance Hole

Air sucked in through the shaft is guided by the protrusion ring, and is released through the balance hole into the self-priming chamber. This allows the impeller to remain in a state of vacuum during self-priming.

D. Seal Blade and Protrusion Ring

The seal blade (interior blade) has the function of sealing the liquid in the pump. The protrusion ring works to guide air sucked through the shaft during self-priming into the balance hole.

E. Self Priming Hole

In a highly vacuumed state, the liquid that is already separated from air in the self-priming chamber goes through this self-priming hole, and is then pushed out by the impeller.

F. Suction Chamber

The suction chamber is composed of the main chamber and the residual chamber. When the pump is stopped, the liquid in the main chamber will suddenly backflow. However, air passed through the siphon break will act as a shield and prevent the liquid in the residual chamber from escaping. This liquid will become the self-priming liquid for the next time the pump is turned on.

G. Suction Cut Hole

This hole allows backflow, which is necessary for the subsequent prime to enter the suction chamber when the pump is stopped. The suction cut hole is located on the wall of the main chamber.

H. Shaft Sleeve and Impeller

With the impeller and the shaft sleeve constructed as one unit, the latter is completely walled off from the liquid. The open impeller is equipped with a back vane, which creates an opposing pressure to balance the pressure around the pump shaft.

I. Self Priming Chamber

Liquid exerted from the spinning chamber is separated into air and liquid by the differences in their gravities in this self-priming chamber. Air goes to the discharge outlet, and the liquid travels to the self-priming opening.

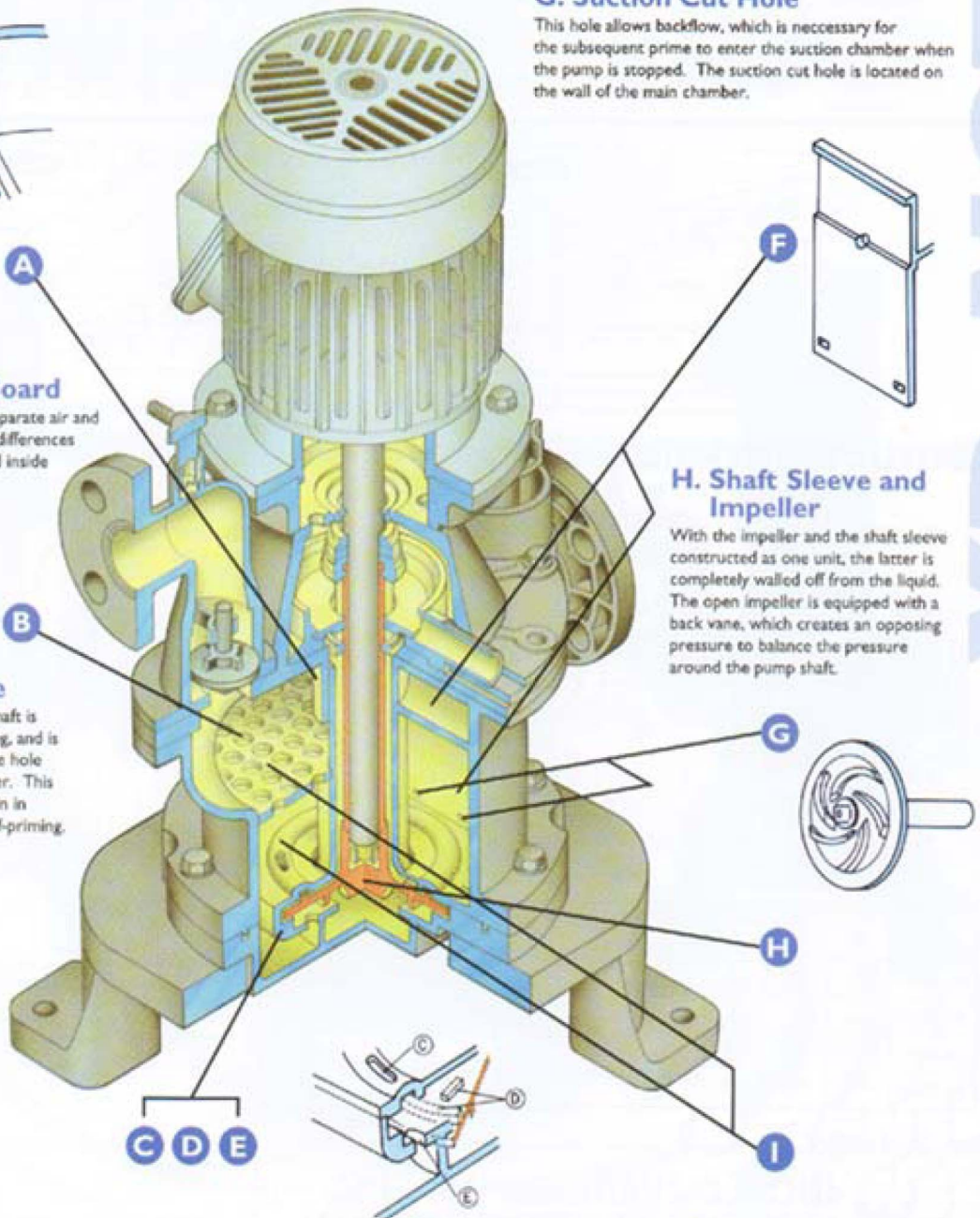

MODEL DESIGNATION & PERFORMANCE SPECIFICATION

EX: **YD - 50 - NSF - P - D**

BORE
TYPE
MATERIAL
SEAL METHOD

Model	Suction Bore		50Hz			60Hz			Suction Head (ft (m))	Material	Seal Method
	Inch (mm)	Inch (mm)	Motor Output HP (kW)	Max. Head meter	Max. Flow lpm	Motor Output HP (kW)	Max. Head feet (m)	Max. Flow gpm			
YD-25NSF	1 (25)	1 (25)	0.5-0.4	11	80	1-0.75	43 (13)	32 (120)	7.8 (2.3)	P : CFR PP	D : DRY SEAL
YD-40NSF	1½ (40)	1½ (40)	1-0.75	12 (100)	100	2-1.5	59 (18)	61 (230)	8.9 (2.7)	K : PVDF	
YD-50NSF	2 (50)	2 (50)	2-1.5	16	330	3-2.2	72 (22)	98 (370)	10.5 (3.2)	E : EPOXY RESIN (ONLY SF)	
YD-80SF	3 (80)	3 (80)	5-3.7	22	710	7.5-5.5	100 (30)	190 (720)	13.5 (4.1)	SUS : STAINLESS STEEL	
YD-100SF	4 (100)	4 (100)	7.5-5.5	26	940	10-7.5	115 (35)	245 (908)	13.5 (4.1)		

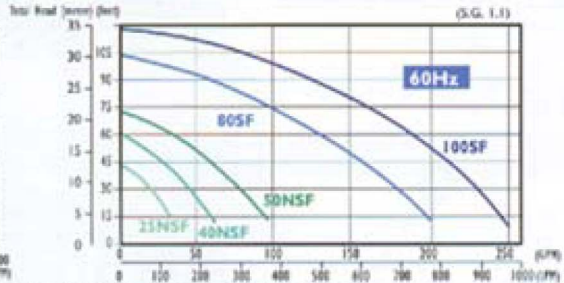
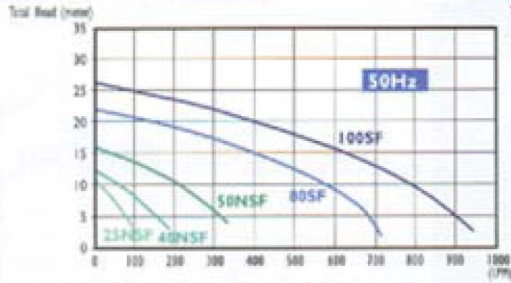

* Above performance data are based on fresh water at 68°F (20°C). The performance will change depending on various conditions.
 * Please inquire if specific gravity and/or temperature is higher, since pump suction head performance may change.
 * Above performance data are based on the usage of standard motor. NSF & SF series pump correspond to high specific gravity liquid by changing motor size.

OUTLINE DIMENSION

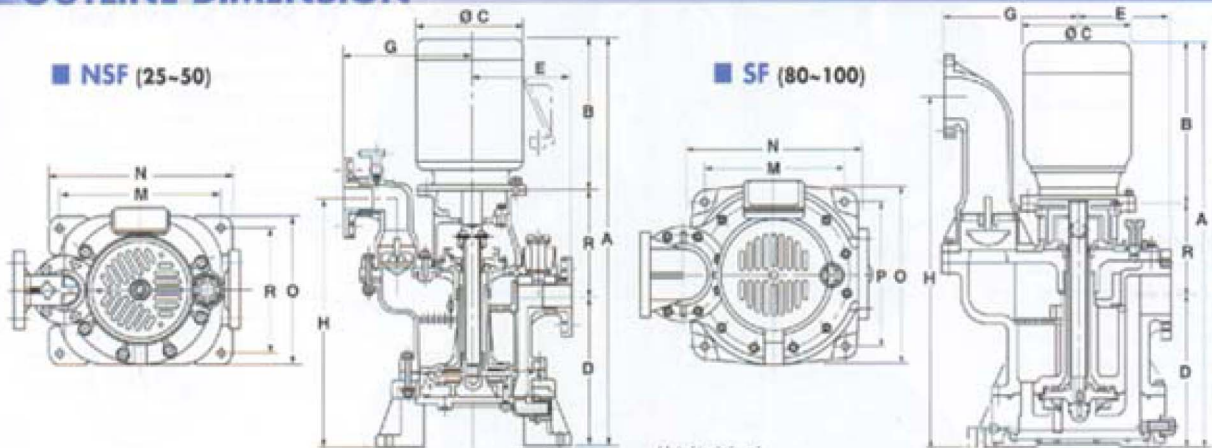

Model	A	B	ØC	D	E	G	H	M	N	O	P	R	Weight (kg)
YD-25NSF	30 (770)	12 (234)	8 (202)	10 (256)	7 (175)	8 (202)	17 (435)	11 (280)	13 (340)	10 (244)	8 (200)	8 (214)	79 (34)
YD-40NSF	30 (770)	12 (234)	8 (202)	11 (272)	7.5 (185)	9 (235)	18 (460)	12 (300)	14 (360)	11 (274)	9 (230)	8 (214)	88 (40)
YD-50NSF	32 (800)	12 (234)	8 (202)	12 (294)	8 (194)	10 (264)	19 (489)	13 (320)	15 (380)	12 (304)	10 (260)	8 (214)	108 (49)
YD-80SF	38 (961)	14 (353)	10 (243)										100 (145)
	40 (1003)	16 (395)	11 (285)	15 (380)	9.5 (240)	14 (347)	32 (810)	14 (360)	18 (450)	14 (360)	14 (360)	9 (228)	178 (173)
YD-100SF													181 (173)
													407 (185)

* Marked (*) dimension varies depending on the motor size.
 * Dimensions and performances may be changed for improvements without notice.
 * For U.S.A. market, pump is supplied with standard NEMA motor and ANSI flange.



Distributed by:

JH Process Equipment, Inc.
 617 Jeffers Circle, Exton, PA 19341
 Business: 610.903.0900 Fax: 610.903.0907