

# SPILLSTOP™

STOP THE SPILL BEFORE IT HAPPENS

## Prevent costly and hazardous spills when AODD pump diaphragms fail.

The patented, fully pneumatic SPILLSTOP system safely captures leaked product and automatically shuts down failed pumps to eliminate costly product loss and prevent hazardous spills. Optional warning alarm and backup pump switchover further minimize system downtime for maximum productivity.

- Compatible with all air operated diaphragm pumps from 1/4" (6.35mm) to 4" (101.6mm)
- Attaches directly to air operated diaphragm pump exhaust
- Fully pneumatic — no batteries or electronics required
- Optional warning alarm and backup pump switchover
- Wide range of chemically resistant body materials
- Variety of standard and ATEX certified models in stock — custom models on request

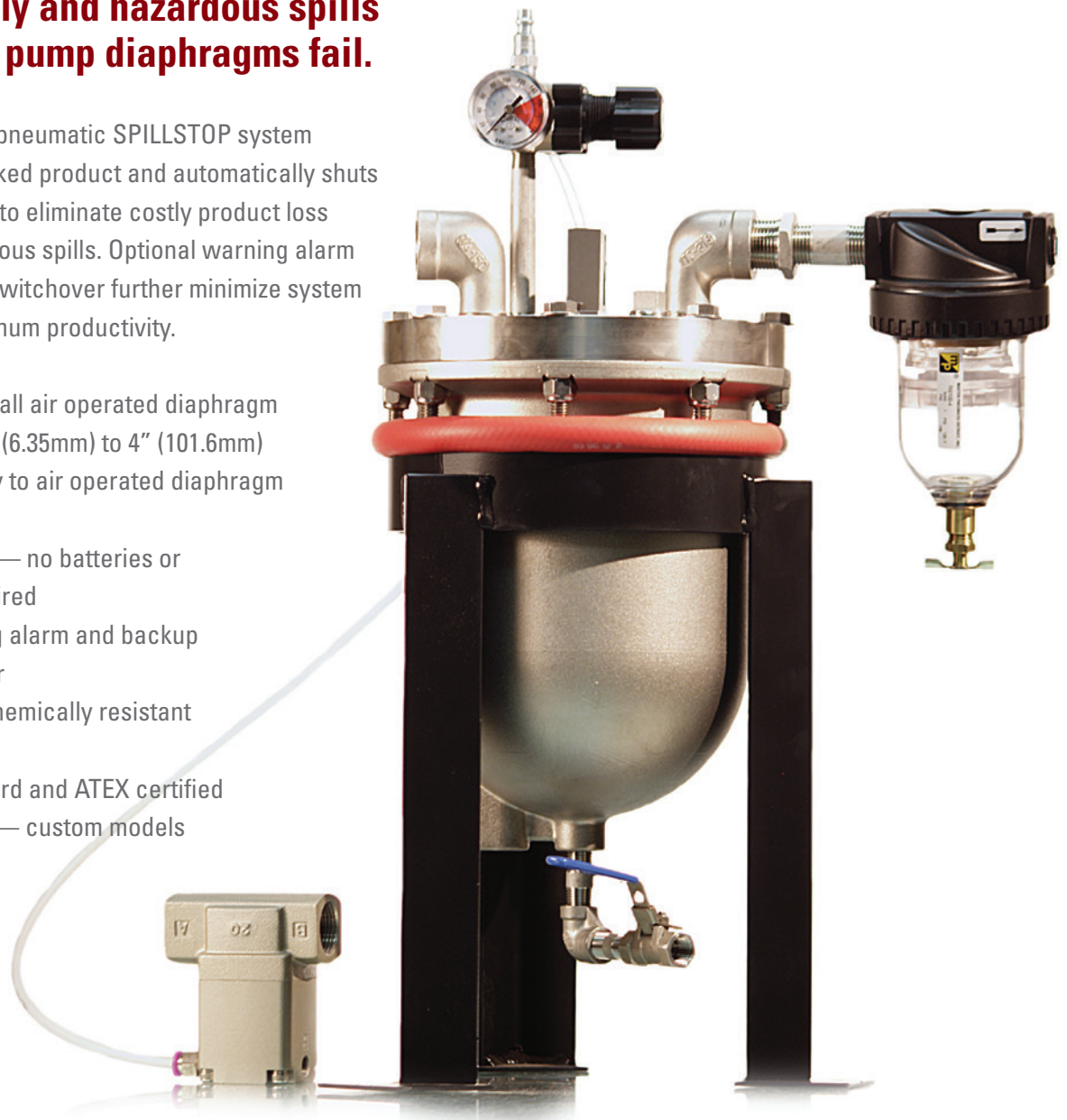

## Safety first.

When diaphragms fail in AODD pumps, dangerous process fluids are expelled from the pump's air exhaust putting employees, equipment and the environment at risk. SPILLSTOP prevents the hazardous spill by safely capturing expelled fluid and shutting down the failed pump.

## Can you afford not to own it?

Unmonitored spills are very costly considering the expense of product loss, system downtime, hazardous cleanup and EPA reporting. By preventing a single spill, the product savings alone would more than pay for your investment in SPILLSTOP. To increase effectiveness, equip your SPILLSTOP with an optional warning alarm whistle, backup pump switch and additional pump shutoff valves for multiple pumps or high suction tank applications.

# SPILLSTOP™

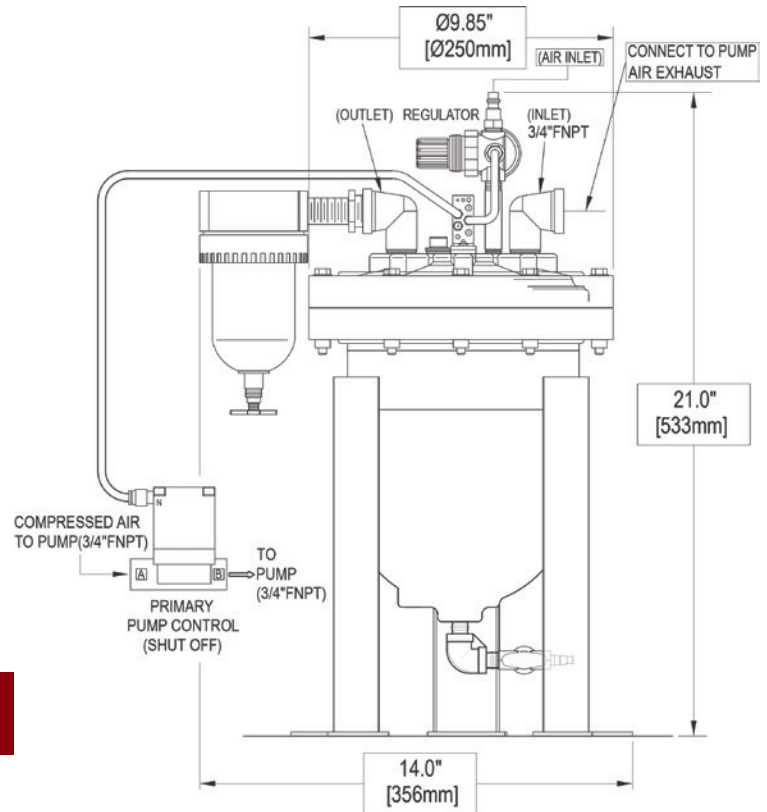

## Calculate Your ROI

Gallons Pumped per Minute	100
Cost per Gallon	\$10
<b>Spill Cost per Minute</b>	<b>\$1,000</b>

Body Materials	Lid Materials	Options
<ul style="list-style-type: none"> <li>■ Polypropylene</li> <li>■ Stainless Steel</li> <li>■ PVDF</li> <li>■ Hastelloy C</li> </ul>	<ul style="list-style-type: none"> <li>■ Noryl</li> <li>■ Stainless Steel</li> <li>■ PVDF</li> <li>■ PTFE Coated Stainless Steel</li> </ul>	<ul style="list-style-type: none"> <li>■ Pneumatic whistle to sound warning alarm</li> <li>■ Pneumatic-to-electric switch to power warning light or control backup pump switchover</li> <li>■ Additional pump shutoff valves for multiple pumps or high suction tank applications</li> </ul>

**PULSATION DAMPENERS ■ SURGE SUPPRESSORS ■ INLET STABILIZERS ■ DIAPHRAGM SEALS/GAUGE GUARDS ■ BACK PRESSURE/PRESSURE RELIEF VALVES ■ LEAK CONTAINMENT/SPILL PREVENTION SYSTEMS**

