

## DB Series: Model DBII

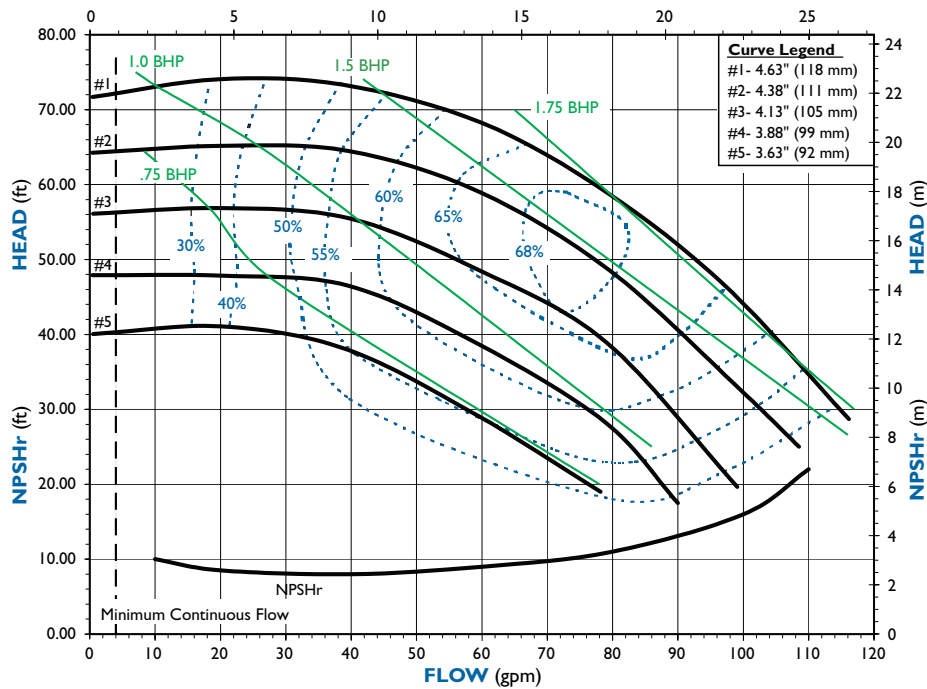

**DBII PERFORMANCE 3450 RPM**  
FLOW (m<sup>3</sup>/hr)



### FEATURES & CAPABILITIES

- + Five-year warranty
- + Extended run dry ability (with carbon bushing)
- + High operating efficiency
- + Easy set, measurement-free drive
- + Polypropylene or PVDF construction
- + Powerful neodymium magnets
- + Close-coupled design
- + Threaded (NPT or BSP), union or flange connections
- + Vertical installation option with IEC motor
- + Back pullout design
- + Mounts to NEMA and IEC motor frames
- + Replaceable shaft
- + ISO 1940 G2.5 balancing
- + CE certified/ATEX available
- + Working pressure up to 90 psi (6.2 bar)
- + Specific gravity over 1.8
- + Viscosity up to 150 cP
- + Polypropylene—180° F (82° C)
- + PVDF—220° F (104° C)

**DBII PERFORMANCE 2900 RPM**

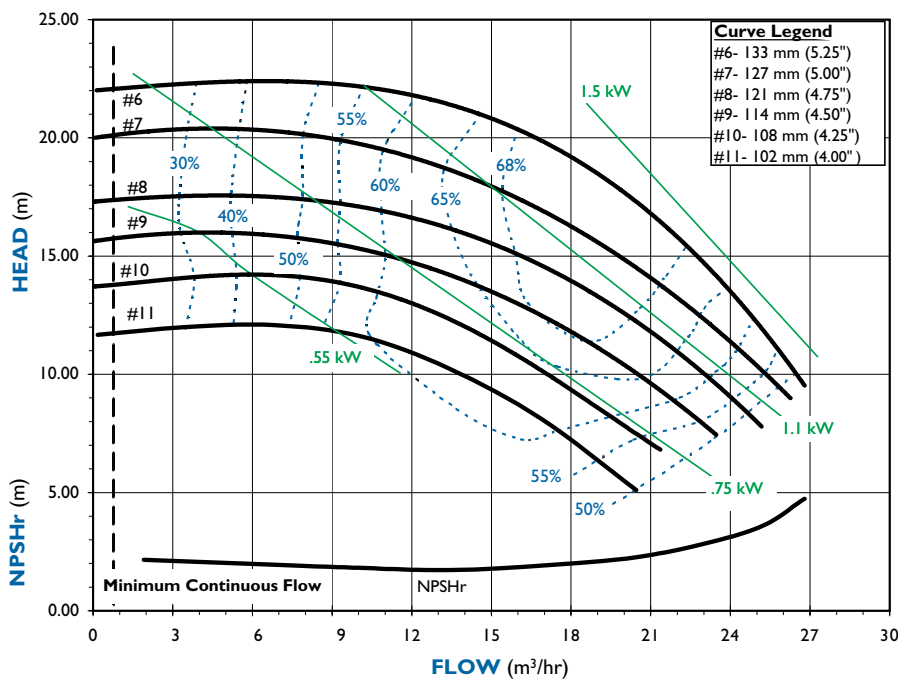

### APPLICATIONS

- + Chemical processing
- + Plating
- + Water and wastewater
- + Electronics
- + Pharmaceuticals
- + Wet scrubber
- + Pulp and paper
- + Heat exchanger

Description	Polypropylene Models	PVDF Models
1 Impeller housing	Glass-fiber reinforced polypropylene	Carbon-fiber reinforced PVDF
1A Impeller housing thrust ring options	High-purity alumina ceramic, silicon carbide	
2 O-ring options	FKM, EPDM, Simriz®, Kalrez®	
3 Impeller	Glass-fiber reinforced polypropylene	Carbon-fiber reinforced PVDF
3A Impeller thrust washer options	Molybdenum disulfide filled PTFE, silicon carbide	
4 Inner drive	Neodymium iron boron magnets encapsulated in unfilled polypropylene	Neodymium iron boron magnets encapsulated in unfilled PVDF
5 Bushing options	Carbon, PTFE, high-purity alumina ceramic, silicon carbide	
6 Shaft options	High-purity alumina ceramic, Hastelloy® C, silicon carbide	
7 Barrier	Glass-fiber reinforced polypropylene	Carbon-fiber reinforced PVDF
7A Barrier thrust ring	High-purity alumina ceramic	
8 Motor adapter	Ductile iron	
9 Outer drive magnet	Nickel-plated neodymium iron boron magnets/steel	

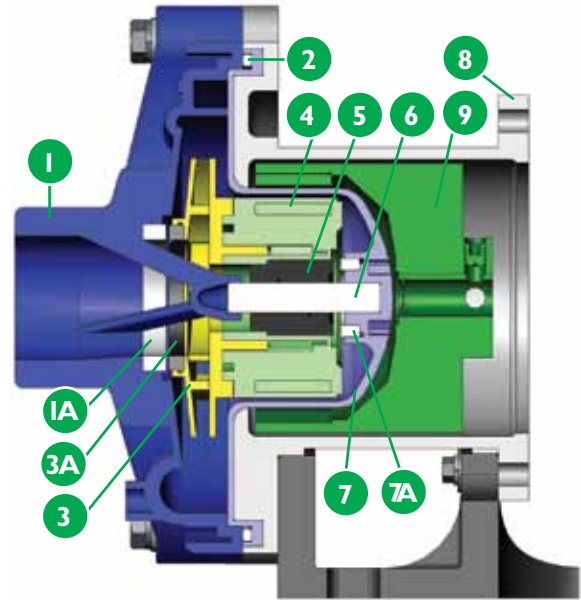

Kalrez® is a registered trademark of DuPont Performance Elastomers  
 Simriz® Perfluoroelastomer is a registered trademark of the Simriz® division of Freudenberg-NOK  
 Hastelloy® C is a registered trademark of Haynes International, Inc.

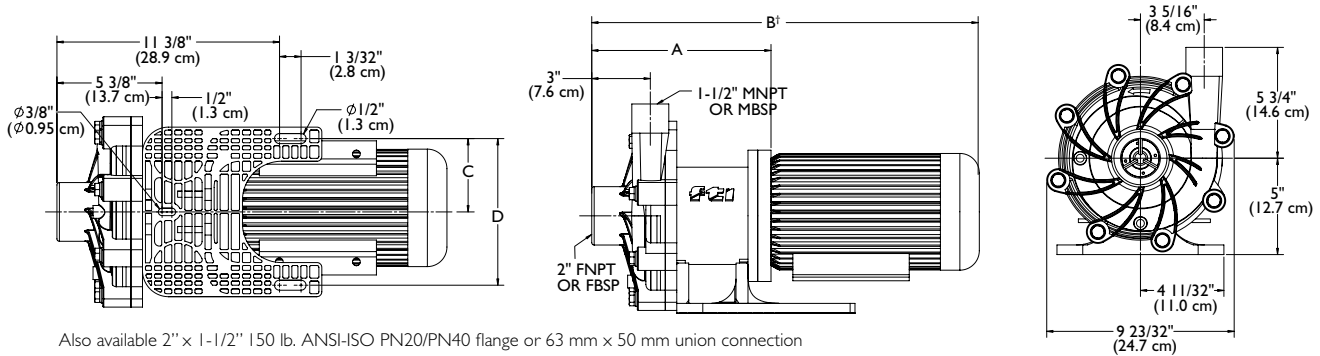

Motor Frame	A	B†	C	D	Weight - lbs. [kg]	
					PP	PVDF
<b>NEMA 56C</b>	8-17/32" [21.7 cm]	20-17/32" [52.1 cm]	3-3/4" [9.5 cm]	7-1/2" [19.1 cm]	21.6 [9.8]	22.8 [10.3]
<b>NEMA 145</b>	8-17/32" [21.7 cm]	18-29/32" [48.0 cm]	3-3/4" [9.5 cm]	7-1/2" [19.1 cm]	21.6 [9.8]	22.8 [10.3]
<b>NEMA 184</b>	9-13/32" [23.9 cm]	22-6/32" [56.4 cm]	3-3/4" [9.5 cm]	7-1/2" [19.1 cm]	25.7 [11.7]	26.9 [12.2]
<b>IEC 80/90 w/B14 or B5*</b>	9-5/32" [23.3 cm]	19-11/16" [50.0 cm]	3-3/4" [9.5 cm]	7-1/2" [19.1 cm]	22.1 [10]	23.3 [10.6]
<b>IEC 80/90 w/B14 ATEX</b>	9-5/32" [23.3 cm]	19-7/8" [50.5 cm]	3-3/4" [9.5 cm]	7-1/2" [19.1 cm]	N/A	23.5 [10.7]
<b>IEC 100 w/B14 or B5*</b>	9-7/32" [23.4 cm]	21-3/8" [54.3 cm]	3-5/32" [8.0 cm]	6-10/32" [16.0 cm]	25.2 [11.4]	26.4 [12]
<b>IEC 100 w/B14 ATEX</b>	9-7/32" [23.4 cm]	21-3/8" [54.3 cm]	3-5/32" [8.0 cm]	6-10/32" [16.0 cm]	N/A	26.6 [12.1]
<b>IEC 112 w/B14 or B5*</b>	9-7/32" [23.4 cm]	21-7/8" [55.6 cm]	3-3/4" [9.5 cm]	7-1/2" [19.1 cm]	25.2 [11.4]	26.4 [12]
<b>IEC 112 w/B14 ATEX</b>	9-7/32" [23.4 cm]	21-7/8" [55.6 cm]	3-3/4" [9.5 cm]	7-1/2" [19.1 cm]	N/A	26.6 [12.1]

Note: Contact factory for dimensions on flanged or union models. \*For B5 weight, add 3 lbs. to 80/90 B14 frame weight and 6 lbs. to 100/112 B14 frame weight.  
 †Varies with motor manufacturer